

# Research and development of pharmaceuticals

## 2/2



# Preformulation - formulation

Formulation of a pharmaceutical composition by appropriate pharmaceutical technology (encapsulation, tableting).



**Pharmaceutical  
Technology**

**Pharmaceutical  
Industry**

**PREFORMULATION**

**PREPARATION DESIGN**

**FORMULATION**

**PREPARATION  
MANUFACTURE**

# Preformulation - formulation

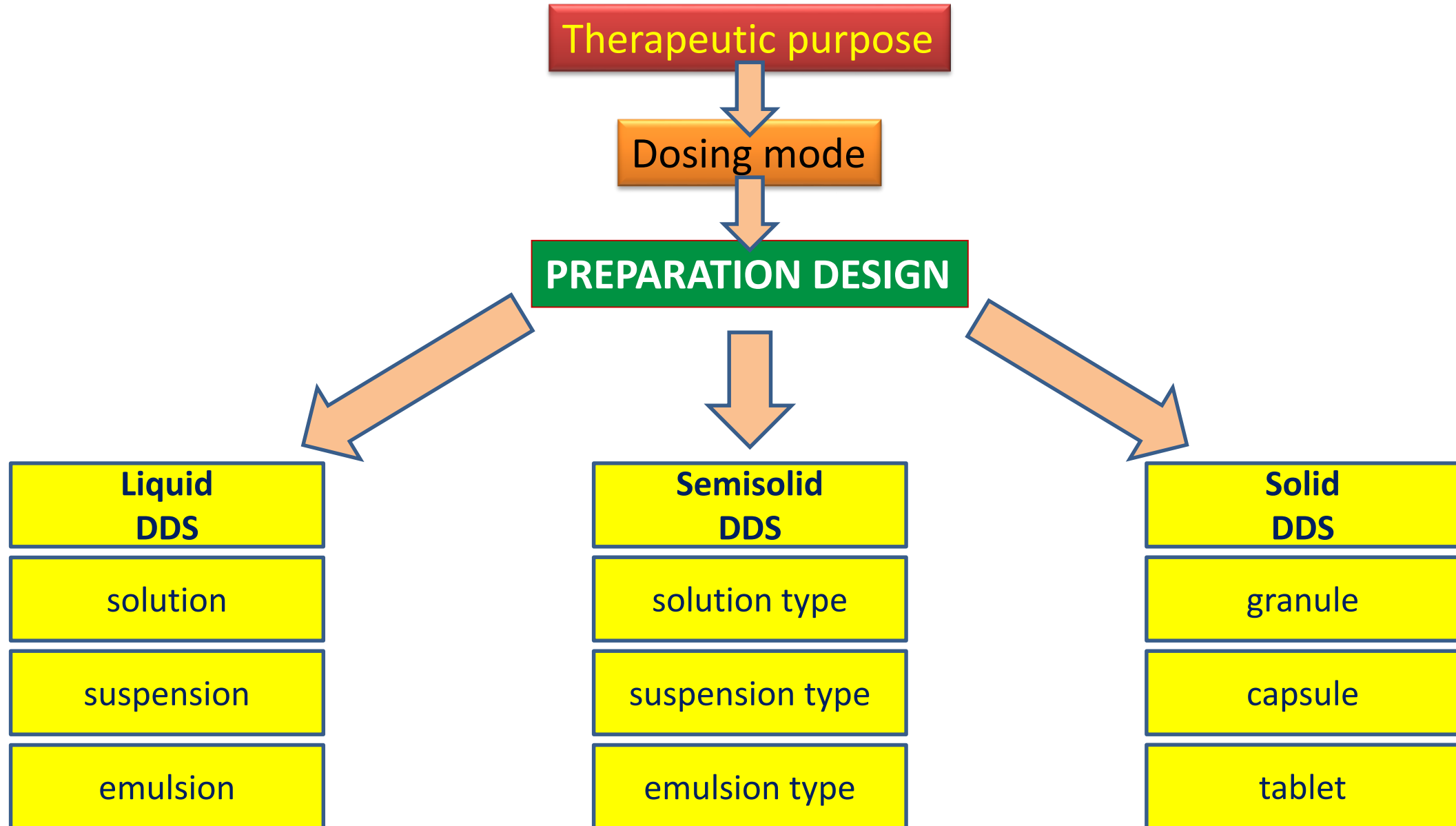

# Preformulation - formulation

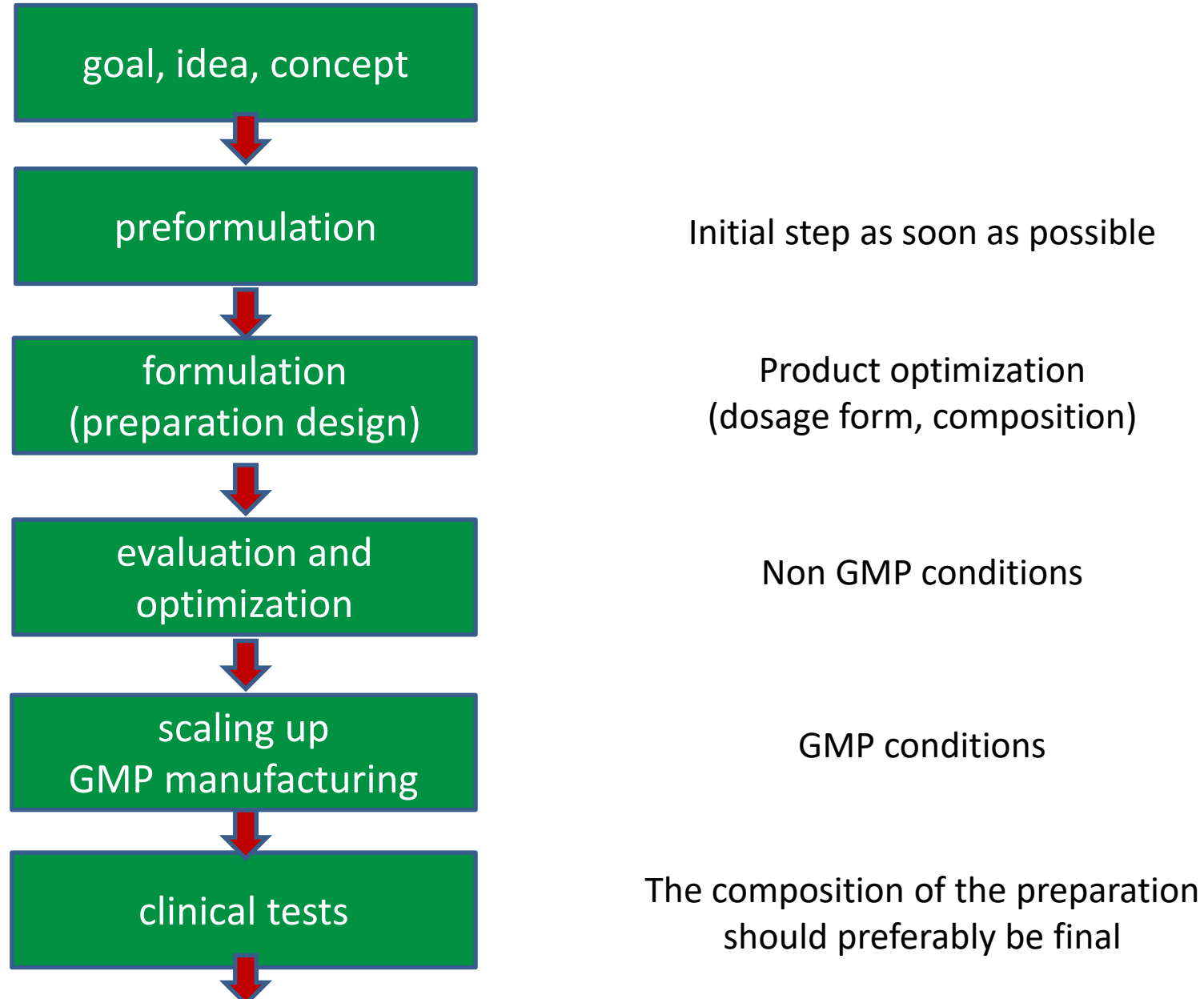

# Preformulation - formulation

## Development phase „0”

- Compound synthesis,
- Physico-chemical tests,
- Analytical tests (identifiability, active substance content),
- Laboratory pre-formulation testing of the active substance,
- Pharmacological and toxicity studies,
- Choice of dosage form,
- Laboratory preformulation studies (amount, composition of excipient).

# Preformulation - formulation

## Clinical Phase I.

- Pharmacodynamic effects in 20-30 healthy volunteers or in patients with a potentially adverse reaction to the safety study,
- Examination of the tolerability of the active substance (determination of tolerable dose),
- Study of the pharmacokinetics of the drug ( $k_a$ ,  $k_e$ ), study of drug metabolism,
- Toxicity studies (mutagenic, teratogenic, carcinogenic),
- Pre-formulation of the pharmaceutical formulation at the pilot plant level (formulation optimization, compatibility),
- Drug stabilization test (degradation specific method), stabilization,
- Preparation of a marketing plan,
- Increasing the size of the product to produce a pilot plant batch.

# Preformulation - formulation

## Clinical Phase II.

- study of the investigational medicinal product in the indication selected on the basis of its pharmacological effect to demonstrate the therapeutic effect of the investigational medicinal product in a volunteer population of 100-300 patients,
- dose-effect relationship study,
- determining the optimal single and daily dose,
- identifying and studying side effects,
- selecting the final dosage form,
- determination of bioavailability,
- pre-tests of packaging technology,
- production of clinical samples at mid-level,
- analytical testing of a pharmaceutical product,
- increase in size to produce the product at the factory level,
- pre-market research.



# Preformulation - formulation

## Clinical Phase III.

- In a large number of volunteering patients in a multi-site, multicentre, statistically designed, randomized and controlled trial design designed to demonstrate the efficacy of the drug candidate on a larger patient population, monitoring for adverse effects to demonstrate the safety of the study drug,
- A comparative study of a registered medicinal product with similar indications,
- Formulation, factory-scale production of pharmaceuticals (formulation optimization),
- Implementation of pharmaceutical packaging technology at farm level,
- Determination of the expiry date of the medicinal product,
- Quality standard preparation, marketing authorization
- Procedure and initiation of the registration process for the preparation,
- Market research.





# Product design

## 1. Preformulation studies

## 2. Formulation and formulation studies

- a) *Laboratory production,*
- b) *optimization and finalization of formulation,*
- c) *pilot size production,*
- d) *stability test of the preparation,*
- e) *validations - including manufacturing process validation and analytical method validation,*
- f) *compilation of documentation materials.*

# Formulation

## Scaling up

- **Lab scale:**

*(Increased lab scale:*

- **Pilot scale:**

- **Industrial scale:**

Batch size

**max. 1 kg**

*3 – 5 kg )*

**15 – 30 kg**

**100 – 300 kg**

*(or more)*

# Phases of product development I.

## Laboratory phase

**Purpose:** To determine the route of administration appropriate to the therapeutic purpose of the drug and to determine the composition of the composition. Selection of excipients in order to achieve the properties of the active substance, the appropriate therapeutic effect and reproducible reproducibility.)

**Activities:** Production of laboratory-level batches, optimization of composition and manufacturing parameters, ensuring reproducibility of quality parameters. Specifying product quality requirements and developing appropriate analytical methods.

**Documentation:** Preformulation plan and report, laboratory development plan, stability plan and report, laboratory prescription.



# Formulation

## Pilot phase

**Purpose:** scale up, reproducibility and finalization of production, validation of analytical methods. Development of the optimum production technology for the specific production equipment.

**Activities:** optimization of production technology, testing of optimized batches, validation of analytical methods, production of documentary batches, stability testing of documentary batches. Specifying product quality requirements and developing appropriate analytical methods. Validation of manufacturing and analytical methods.

**Documentation:** optimization plan and report, manufacturing sheet, analytical method validation plans and reports, stability plan and report, development report



# Formulation

## Industrial phase

**Purpose:** Finalization of factory production, development of optimal manufacturing technology for the given production equipment, validation of production

**Activities:** optimization of manufacturing technology, measurement of optimization batches, production of validation batches, analytical testing of validation batches

**Documentation:** optimization plan and report, plant validation plan and report, factory production report, commissioning final report.



# Formulation

**Batch:** batch from a given production that is essentially the same product.

**The condition of a "release" of a lot is:** according to the quality requirement of the product, tested and certified.

## Important quality parameters:

- appearance (color, shape, surface...)
- weight deviation
- standard deviation of active substance content (for the same active ingredient)
- dissolution data dispersion
- etc. ...

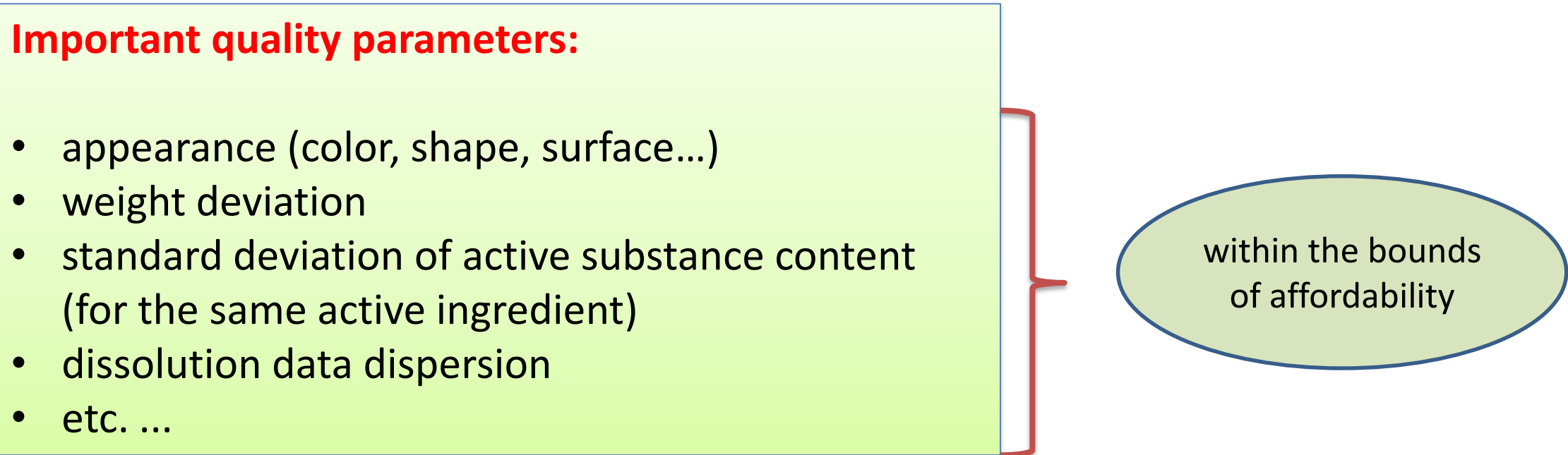

within the bounds  
of affordability

# Pharmaceutical Industry

## The driving force of R&D

1. **The sick person** (improvement of therapy, new therapies)
2. **Scientific knowledge** (basic and applied research)
3. **Economic success** (economic profit, R&D)



financial aspects



professional aspects

# Pharmaceutical Industry

Licensing considerations

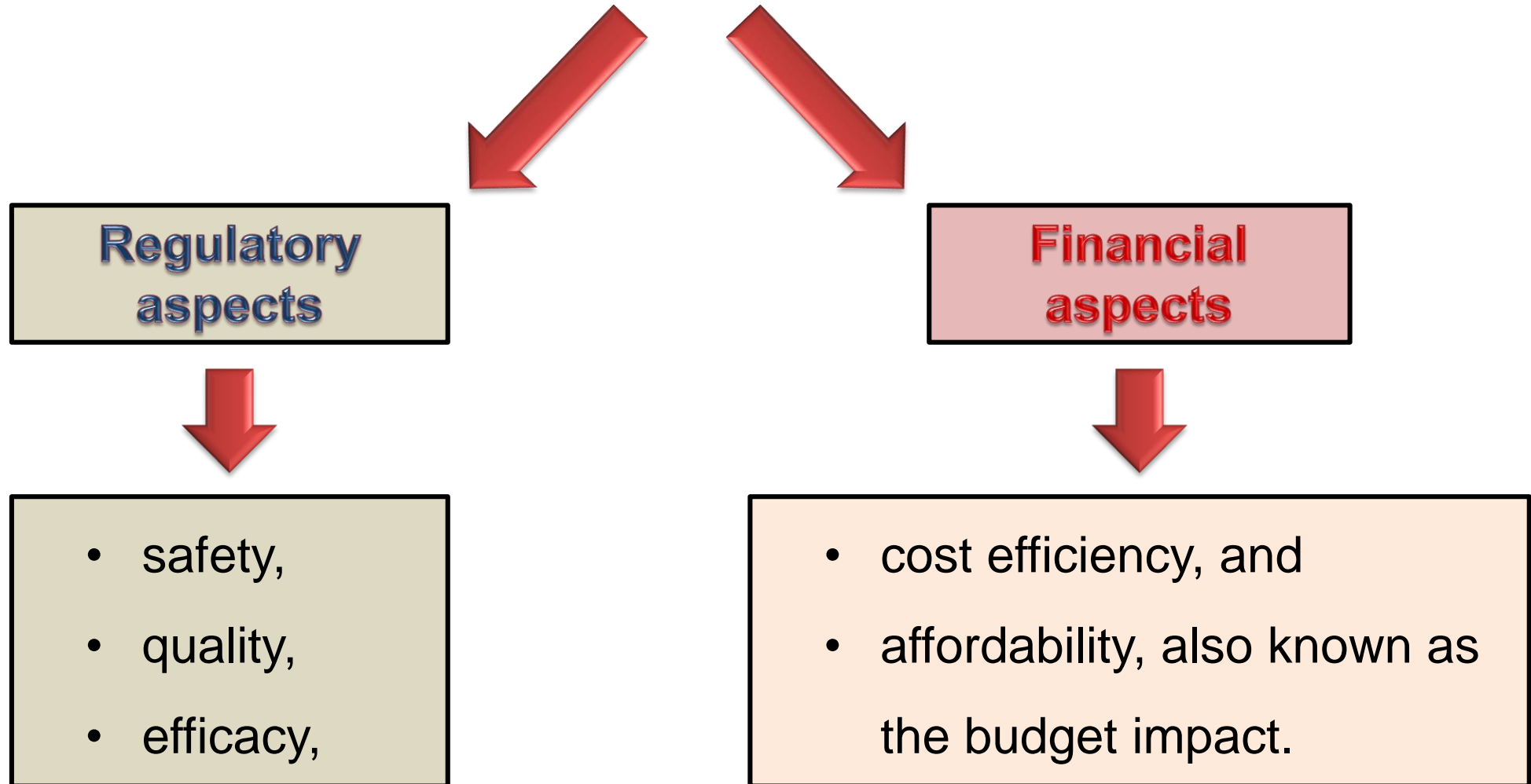



# Pharmaceutical Industry

## Main directions of research and development

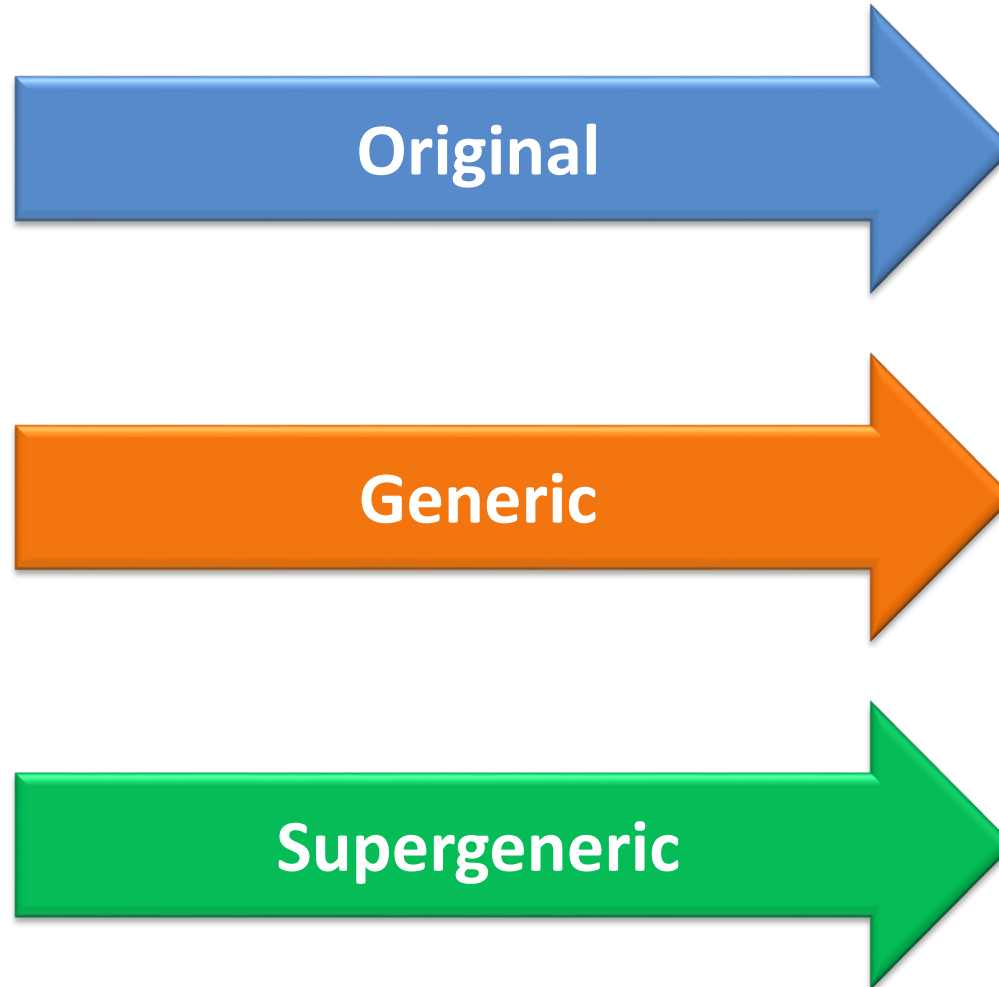

# Original preparations

## What do we expect from an original drug substance?

- Its mechanism of action should be as new as possible at molecular level.
- Use it safely.
- Provide solutions to real and as wide-ranging health needs as.
- To be more effective in healing or prevention and / or to be used in a new therapeutic area.
- Selling on the market should be a return on investment.

# Original preparations

## *Production and use of pharmaceutical materials*

Original research is becoming more expensive.

Cost-effective research methods have not been developed.

The pharmaceutical industry is developing fewer new active substances using more and more funds.

# Original preparations

## *Original drug research*

**The concept of medicine also changes.**

In addition to the previously used minerals, herbs, animal substances and their mixtures, extracts, we can now use immunobiological substances, toxins, trace elements, synthetic or semi-synthetic products, as well as biotechnologically produced products, but also radioactive medicinal products.

# Original preparations

## *Biopharmaceuticals*

The significant advances in molecular biology and genetics have led to the research and manufacture of biopharmaceuticals.

Realized

- gene expression techniques,
- Launching of monoclonal antibody production.

Biological therapy includes:

- cell therapy,
- gene therapy.

New type of mechanism of action, test methods, evaluation.

# Original preparations

## *New drug delivery systems* *Cancer therapy*

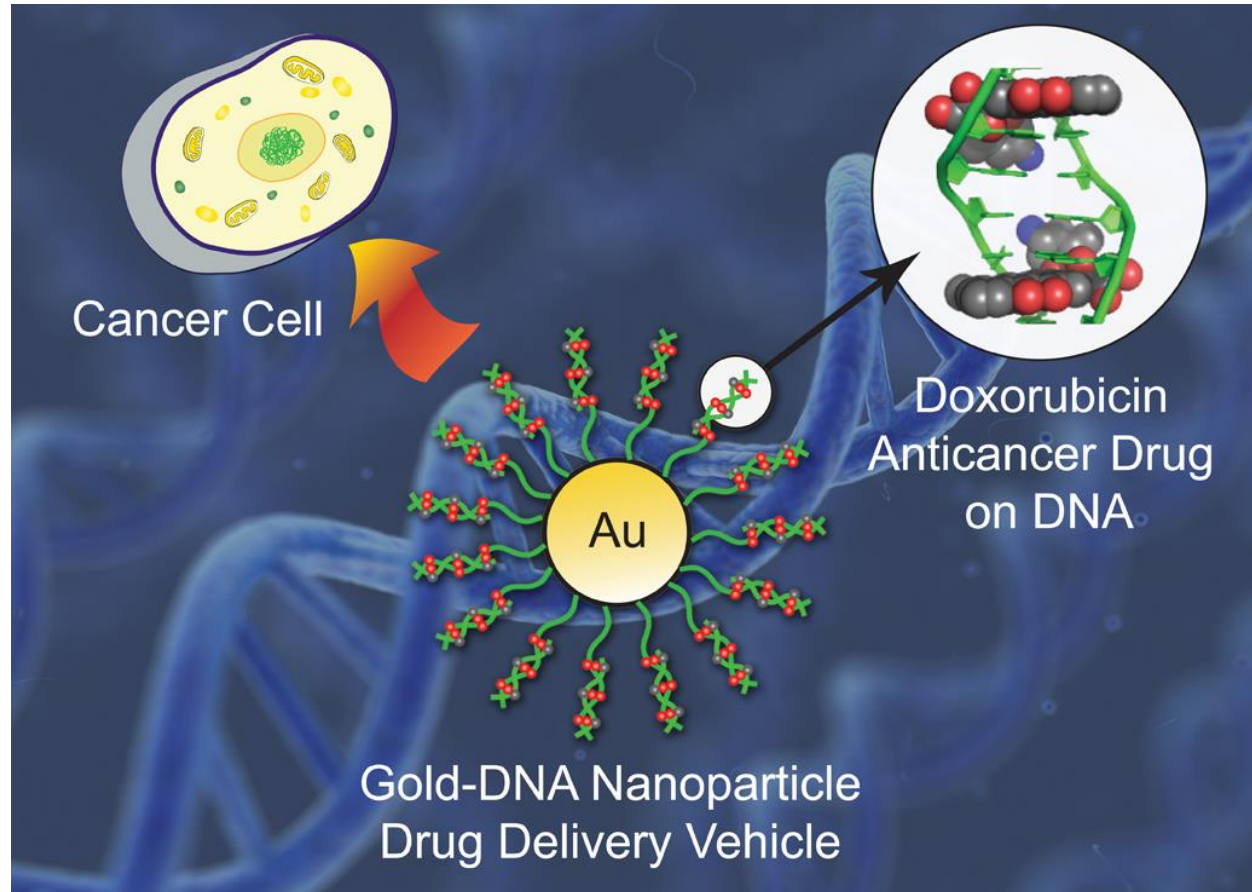

To reduce the toxicity of various drugs by changing the biodistribution of the drug away from sensitive organs.

# Original preparations

*New drug delivery systems*  
*Nanotechnology*

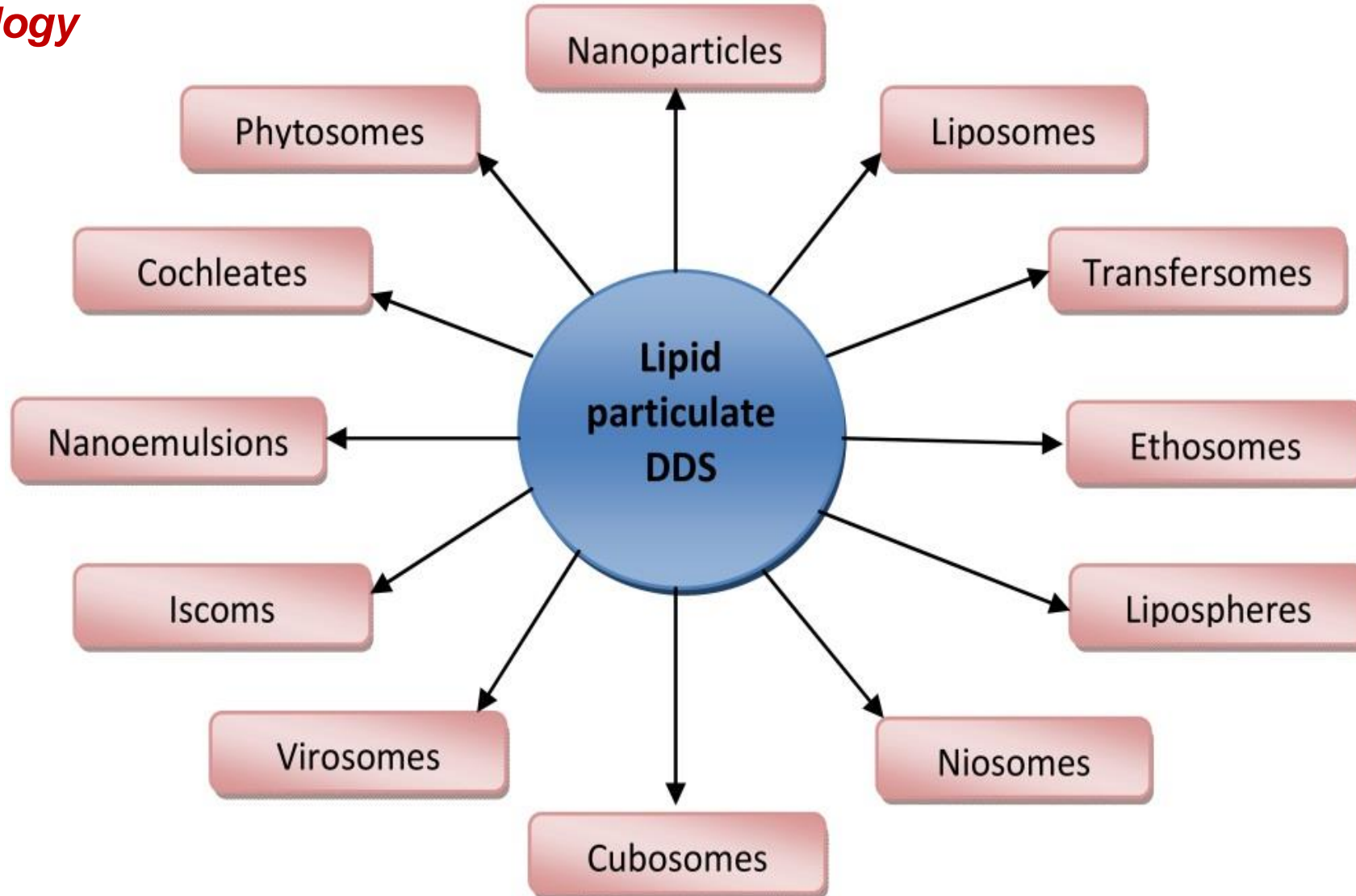

# Original preparations

## New drug delivery systems Nanotechnology

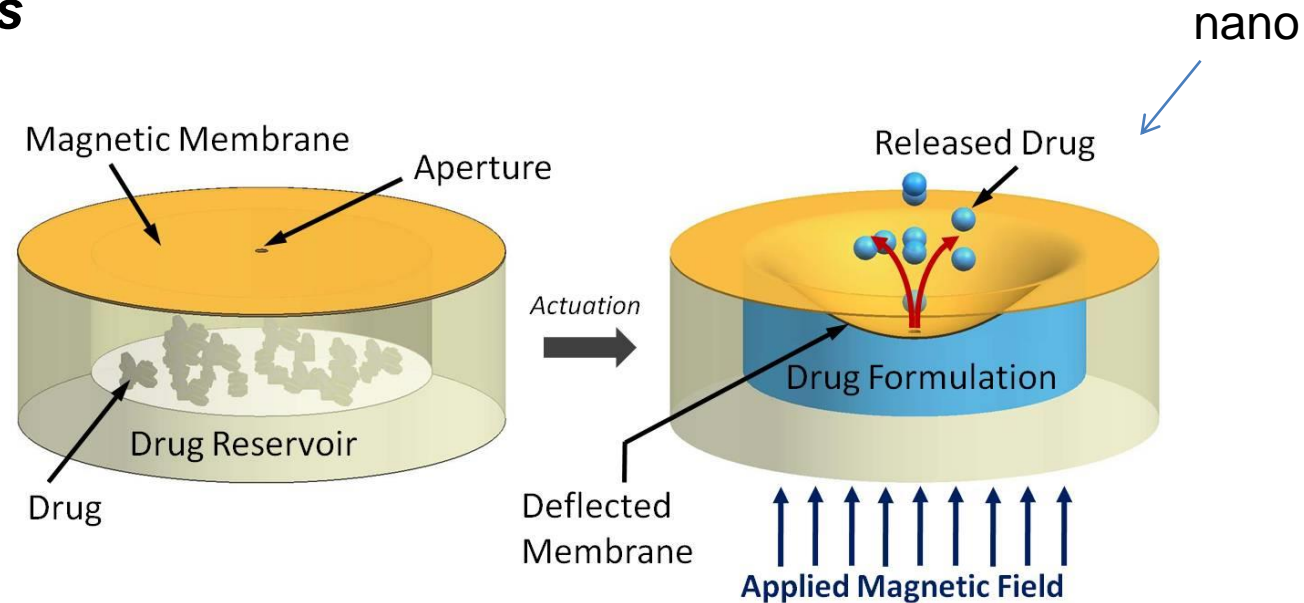

Elastic magnetic polydimethylsiloxane (silicone) membrane. A magnetic field causes the membrane to deform and discharge a specific amount of the drug.

Diabetic retinopathy is the leading cause of vision loss among patients with diabetes. The disease is caused by the unwanted growth of capillary cells in the retina, which in its advanced stages can result in blindness.

A device was developed that can be implanted behind the eye for controlled and on-demand release of drugs to treat retinal damage caused by diabetes.



# Original preparations

## *New drug delivery systems* *Chronotherapy*

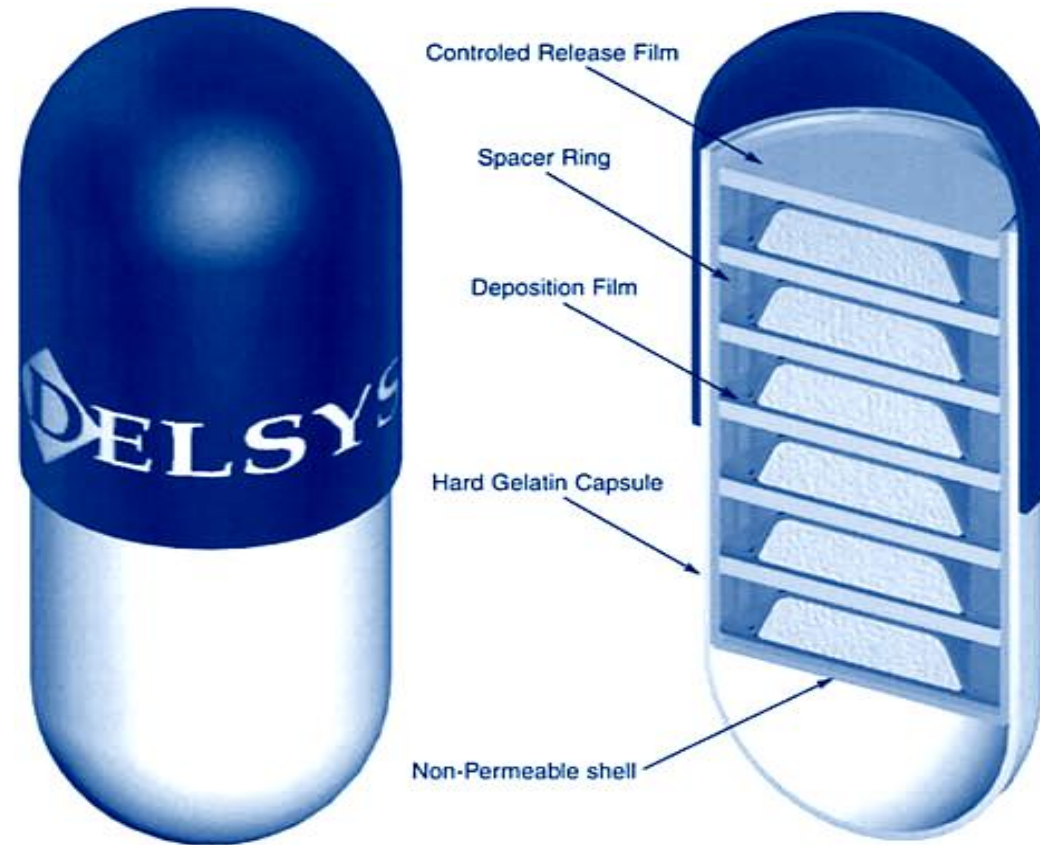

# Original preparations

## New drug delivery systems *Electronics*

MICRONEEDLES DRUG PATCH

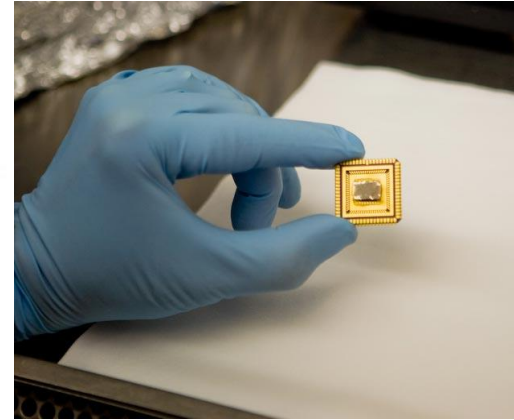
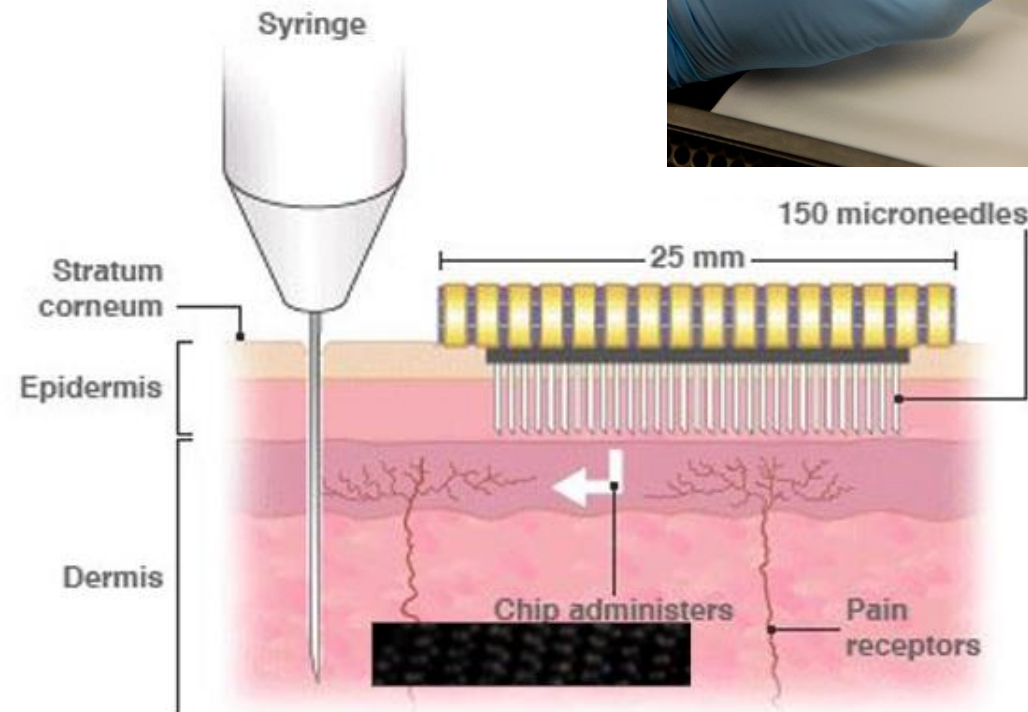

HP and Crospon have developed a skin patch which uses microneedles that barely penetrate the skin. The microneedles can replace conventional injections and deliver drugs through the skin without causing any pain.

# Original preparations

## *New drug delivery systems* *Electronics*



To improve patient compliance, and to prevent overdose an „e-Dose counter” was developed. The e-Dose counter displays the remaining dose inside the container, and allows only a set number of doses over a period time.

# Original preparations

## *New drug delivery systems* *Electronics*

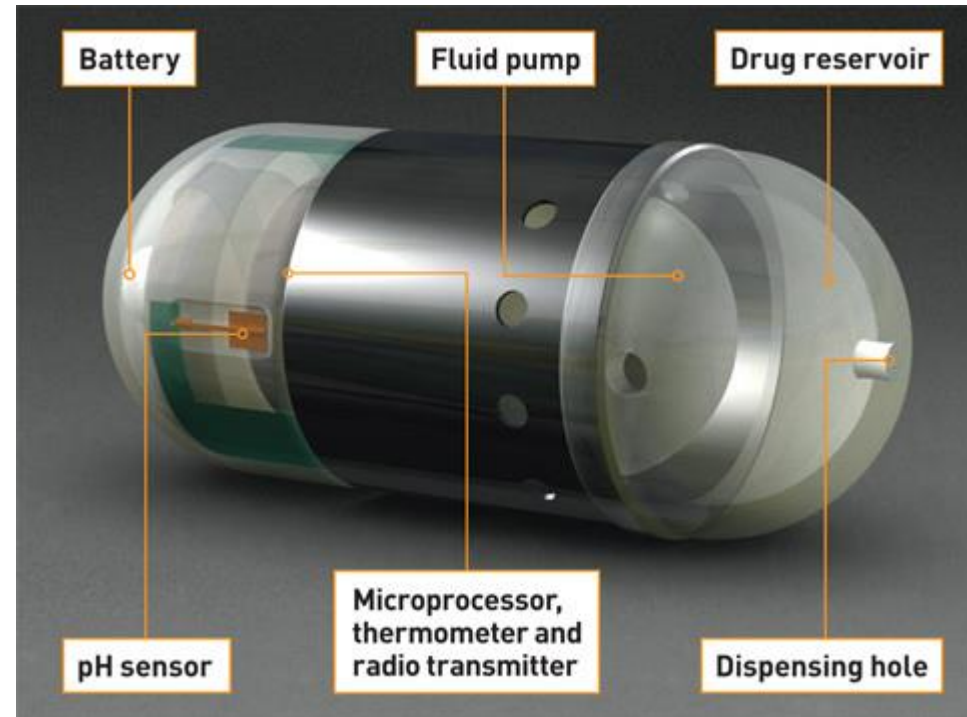

The i Pill, a plastic capsule taken with food or water, is intended to travel through the digestive system naturally, typically within about 24 hours, dispensing its medicine at specific locations along the way.

# Original preparations

## *New drug delivery systems* *Electronics*

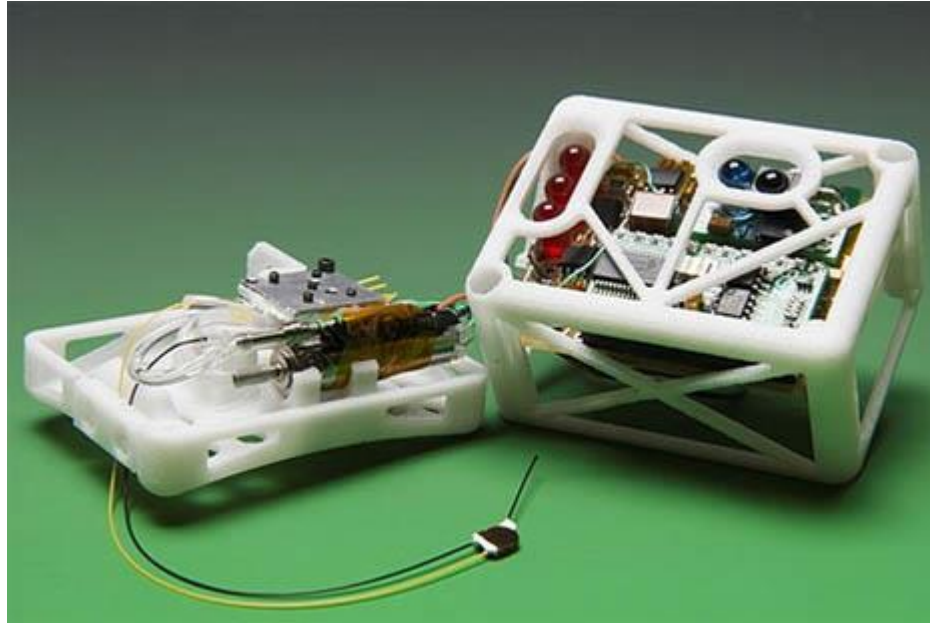

The programmable wearable microfluidic drug delivery system consists of a housing with control electronics, battery and pump, and connecting tubing. The pump is implanted in the temporal bone, with the tube leading onto the cochlea, injecting drugs from the tip. Drug dosing can be precisely timed.

# Generic preparations

## Definition

Copies of the original medicinal product, so called. generic medicines can be marketed to other manufacturers after the patent expires.

Generics contain an active ingredient that has expired patent protection.

(Since 1994, Hungary has patent protection for active substances.)

# Generic preparations

## Pharmaceutical Therapeutic Aspects of Development

- Dose reduction (use of the body, side effects),
- Perfect fit to the biological environment, taking into account the site and circumstances of absorption,
- Perfect fit to therapeutic expectations (eg systemic, local, rapid, sustained, targeted),
- Reproduction of optimized dissolution and absorption of the product in therapeutic practice,
- Deliberate and planned regulation and reproduction (degradation, elimination) of further fate of the medicinal product.

# Generic preparations

## Possibilities for development 1/2

1. Provide the right dosage form with the right dosage form,
  - a) Use the right composition,
  - b) If necessary, the active ingredient is converted
2. By controlling solubility (eg complex formation, salt formation, solubilization,)
3. By controlling the dissolution rate (eg micronization, nanonization, molecular dispersion, amorphization)
4. If necessary, adjust the absorption (eg acceleration, deceleration),
5. Controlling the drug release profile (eg trip tkiold, tlag)
6. Providing the desired blood level profile (eg tlag, tmax, cmax, teffect),
7. Reduce or increase the amount of active ingredient needed in the preparation,
8. Reducing unwanted effects of the pharmacone (eg, local irritation),
9. Eliminate incompatibilities (compatibility with pharmaceutical ingredients),
10. Working to develop a biocompatible drug delivery system.



# Generic preparations

## Possibilities for development 2/2

11. achieving adequate bioavailability,
12. facilitating dosage control, safety of therapy (compliance, adherence, persistence),
13. stabilization of the preparation (storage under the prescribed conditions, preservation of the physical, chemical, pharmacological and biopharmaceutical quality parameters necessary for the effect of the drug within the expiration date), optimization of the shelf life,
14. ensuring a degree of purity appropriate to the new form of administration,
15. development of modern production technology,
16. optimization of technological parameters required for production,
17. providing the product with a modern, attractive appearance (preparation, packaging),
18. optimize production costs to ensure product quality,
19. cost-effectiveness of production, also in terms of spreading additional costs.

# Generic preparations

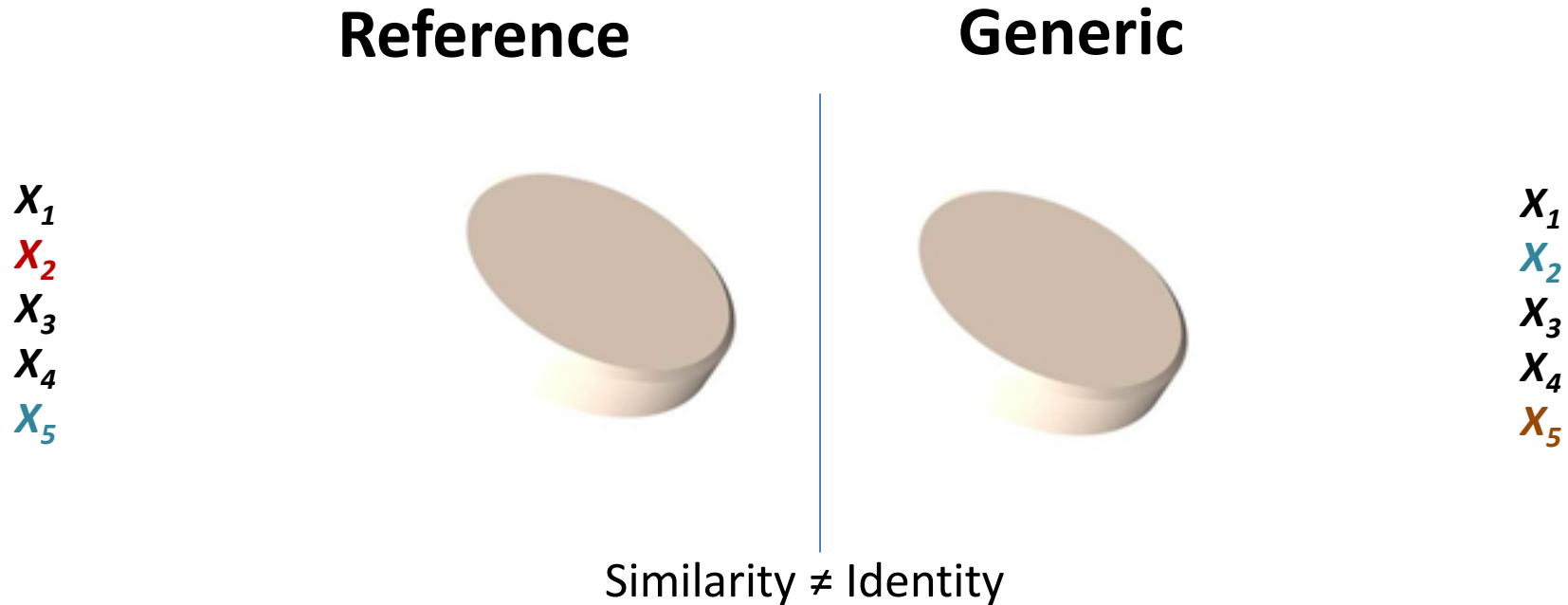

Some parameters may differ, others may differ.

In what parameters are the differences allowed and in which not?

What is the permissible deviation in the different parameters?

# Generic preparations

## Aim of generic development

The purpose of the development is to develop a product of „**essentially similar**” quality to the reference (original or generic) product.

# Generic preparations

## Main steps of development

- Defining the main parameters (in order to maintain the therapeutic aim of the drug)
  - active substance,
  - pharmaceutical form,
  - for excipients
- Determination of the optimal formulation of the excipient
- Optimization of production technology (for the given production equipment, the production of critical production parameters)
- Development (or retention) of appropriate test methods
- Defining product quality requirements (providing critical values).
- Validation of manufacturing and analytical methods

# Generic preparations

## What do we expect from a non-original (generic) drug?

- 1) No longer under patent protection,
- 2) Its mechanism of action should be known at the molecular level, safe to use,
- 3) Addressing real and as wide-ranging health needs as possible,
- 4) Be effective in healing or prevention, or possibly applied in a new therapeutic area (supergeneric),
- 5) Return on the costs of selling on the market.

# Generic preparations

It is a basic requirement for a generic formulation to have a substantially **similar therapeutic effect** to the parent formulation in a **similar formulation**, i.e., to be similar in time and degree of bioavailability to the reference formulation.



# Generic preparations

## Possible causes of different characteristics of generic drugs

- same active ingredient but different excipients
- impurities in the same active substance with different amounts and possibly different chemical structures
- different quality, stability, etc. of the preparation.



# Generic preparations

## Therapeutic equivalence

The most important therapeutic criterion for therapeutic (in vivo) equivalence of pharmaceutical formulations is that treatment of a patient on one agent can be continued with the other agent at any time without further adjustment.

This requires that formulations containing the same active ingredient have the same clinical efficacy and tolerability.

Proof of bioequivalence is also required to demonstrate therapeutic equivalence.





# Generic preparations

## Bioequivalence

**According to the European regulatory directive, two pharmaceutical preparations are bioequivalent when**

- they are pharmaceutically equivalent, or
- each other's pharmaceutical alternatives, and
- after administration of the same dose
- their bioavailability is similar to that of their effects are essentially the same in terms of efficacy and harmlessness.



# Generic preparations

## Pharmaceutical equivalence

- The same active ingredient,
- Equal quantity,
- Same pharmaceutical formulation (pharmaceutical formulation)  
(the excipient composition may be different).

This does not necessarily imply bioequivalence, since differences in excipients and manufacturing may result in different dissolution or absorption rates.

# Generic preparations

## Pharmaceutical alternatives

The active ingredient is the same but may be in different

- amounts, or
- formulation (tablets, capsules) or
- the chemical form of the active substance (salt, ester, etc.)

Where the reference product contains the same substance responsible for the same effect in the form of another salt, ester or other derivative, the applicant for authorization shall demonstrate that the two forms have the same pharmacokinetic and pharmacodynamic profile, and thus have the same potency and toxicity.



# Generic preparations

## Bioequivalence

The bioequivalence between the original and the generic formulation is essentially biopharmaceutical equivalence.

Two products are bioequivalent if

1. their dose is the same,
2. their bioavailability is similar to
3. results in essentially the same effect and toxicity of the two products.

(Bioavailability: the rate and rate at which an active substance in a preparation reaches the site of action or circulation)



# Generic preparations

## Bioequivalence index

The bioequivalence index describes the difference between the plasma concentration-time function of the reference and the test preparation.



# Generic preparations

## Study of bioequivalence

To determine bioequivalence, the characteristic values of the drug release and blood levels are compared.

The bioequivalence study is a comparative bioavailability study (usually a single but sometimes multiple dose blood test and statistical evaluation of the results) obtained with the same doses of the reference and generic formulations.



# Generic preparations

## Study of bioequivalence

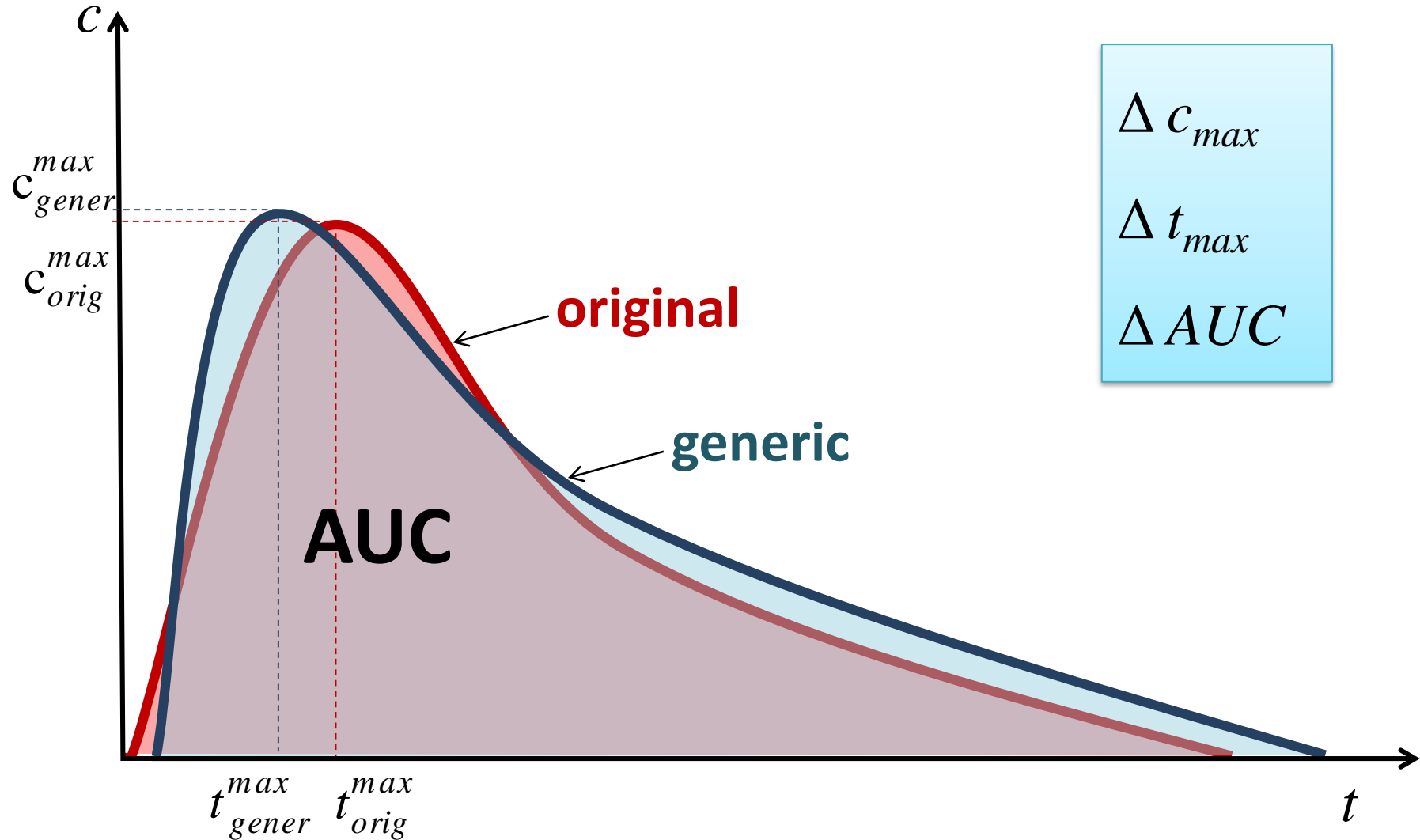

# Generic preparations

## Study of bioequivalence

Generic drug bioequivalence testing is performed on twenty healthy healthy volunteers who first take one drug and then the other one a few weeks later, in the prescribed manner and time.

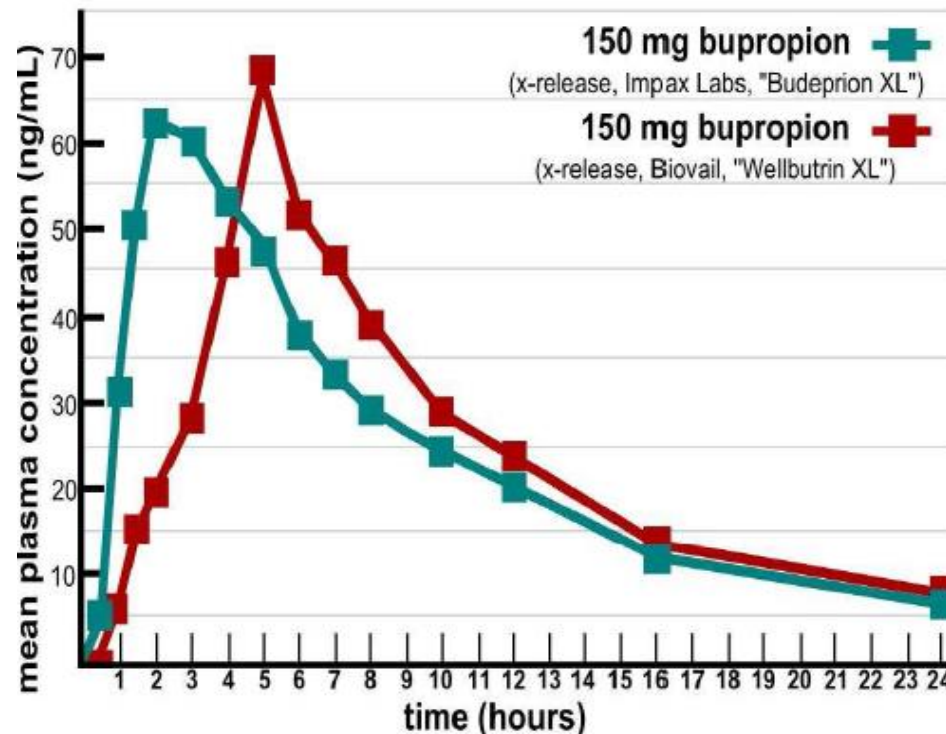

$t_{max}$  identical

$C_{max}$  identical

$AUC$  identical

$p=0,05\%$



# Generic preparations

## Study of bioequivalence

Allowed margin for AUC +/- 20%

Is the margin of tolerance too wide?

Ex: 40 mg dose

lower limit 80% = 32 mg;

upper limit 120% = 48 mg;

difference 48-32 mg = 16 mg.

**For the vast majority of generic drugs on the market, the difference is no greater than +/- 3%.**

**For drugs with a narrow therapeutic window,  
small increases in plasma levels can lead to significant toxicity!**

# Generic preparations

## Medicines with narrow therapeutic windows

- Aminophylline / Theophylline
- Antiarrhythmics
- Antiepileptics (Except benzodiazepines)
- Cytotoxics
- Immunosuppressive drugs
- Lithium
- Thyroxine
- Tricyclic antidepressants
- Warfarin

Drug substitution is recommended with increased control, in particular, inadequate or overdose may be associated with clinically or economically significant adverse health effects or adverse clinical events (eg organ transplant, epileptic patients).

# Generic preparations

## Examination of bioequivalence 1/3

1. In the case of **rapid release** (tablets, capsules, suspensions) the bioequivalence test can be carried out between different dosage forms eg. tablet, capsule,
2. In the case of oral formulations with **high water solubility**, the bioequivalence test may be omitted in some cases,
3. Bioequivalence testing is generally **not required for oral solutions**,
4. For systemic **non-oral formulations** bioequivalence testing (eg. transdermal) is required.



# Generic preparations

## Examination of bioequivalence 2/3

5. **Modified release and transdermal** dosage forms: bioequivalence study is required
6. In the case of a **fixed combination**, the bioequivalence test shall be carried out for each component
7. **Inhalation gas**: no bioequivalence study required
8. **Parenteral Solutions**: Bioequivalence studies are not required if aqueous solutions of the same concentration are administered intravenously
9. If not iv. but other **parenteral formulations** of the same solution type with the same or similar excipients do not require bioequivalence testing



# Generic preparations

## Examination of bioequivalence 2/3

10. For topical formulations (where the formulation is non-systemic, oral, nasal, ophthalmic, rectal, vaginal, inhaled, cutaneous, etc.), therapeutic equivalence with **comparative pharmacological and clinical studies should be demonstrated** instead of bioequivalence testing based on blood levels.



# Generic preparations

## In vitro equivalence

For in vitro equivalence, the behavior of the formulations measured in dissolution and membrane transport assays is the same.

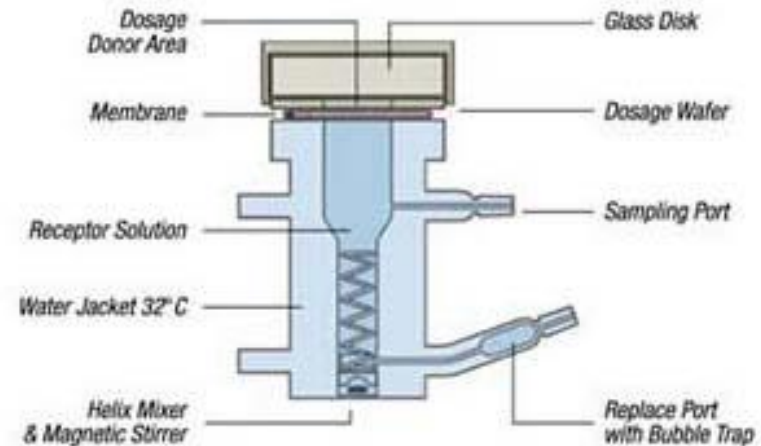
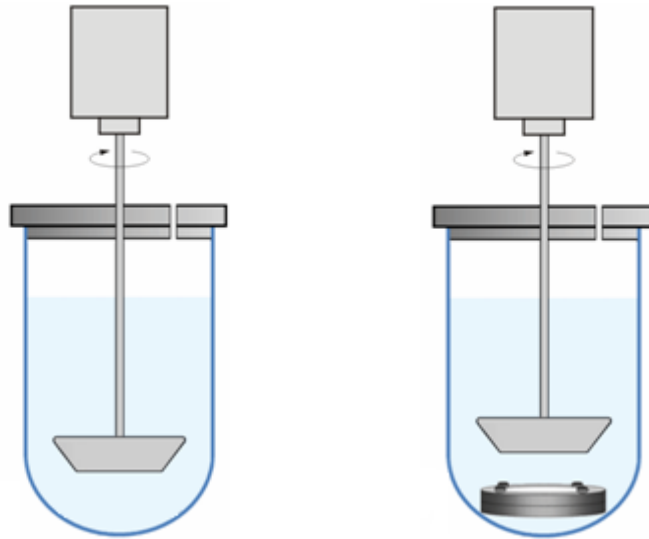

# Generic preparations

## In vitro equivalence

**Dissolution of bioequivalent formulation:** Fitting Factors ( $f_1, f_2$ ).

The method compares the percent dissolution values of the reference and sample formulations at a given time and shows the difference or similarity between the two dissolution curves.

*$f_1$  = difference factor*

$$f_1 = \frac{\sum_{i=1}^n (R_i - T_i)}{\sum_{i=1}^n R_i} \times 100$$

*$f_2$  = similarity factor*

$$f_2 = 50 \lg \left\{ \left[ 1 + \frac{1}{n} \sum_{i=1}^n (R_i - T_i) \right]^{-0,5} * 100 \right\}$$

$n$  = number of sampling times,

$R_i$  = average active ingredient dissolution from **reference product** at time  $i$ ,

$T_i$  = average active ingredient dissolution from **test preparation** at time  $i$ .

# Generic preparations

## Model independent rating - Similarity factor ( $f_2$ ):

The equivalence of the dissolution profiles shall be demonstrated by calculation of a similarity factor  $f_2$ .

**No profile test and  $f_2$  calculation is required if: > 85% dissolves in 15 minutes**

$$f_2 = 50 \log \left\{ \left[ 1 + \frac{1}{n} \sum_{i=1}^n w_i (T_i - R_i)^2 \right]^{-0,5} \right\} \times 100$$

$n$  = number of sampling times,

$R_i$  = average amount of active substance dissolved in the reference preparation at time  $i$ ,%

$T_i$  = average amount (in%) of active substance dissolved (or modified) in the test preparation at time  $i$ .

**If the similarity factor is  $f_2 > 50$ , then the dissolution profiles can be considered as similar.**



# Generic preparations

## In vitro similarity

	30 min	60 min	90 min	180 min	f <sub>2</sub>
Reference	34,92	59,5	79,27	95,08	
Test 1	40,34	67,15	87	97,73	60,04
Test 2	49,3	65,33	86,75	102,83	51,08
Test 3	25,8	50,64	67	88,6	51,19
Test 4	15,08	59,5	79,27	95,08	50,07
Test 5	43,39	77,96	86,33	95,58	48,05

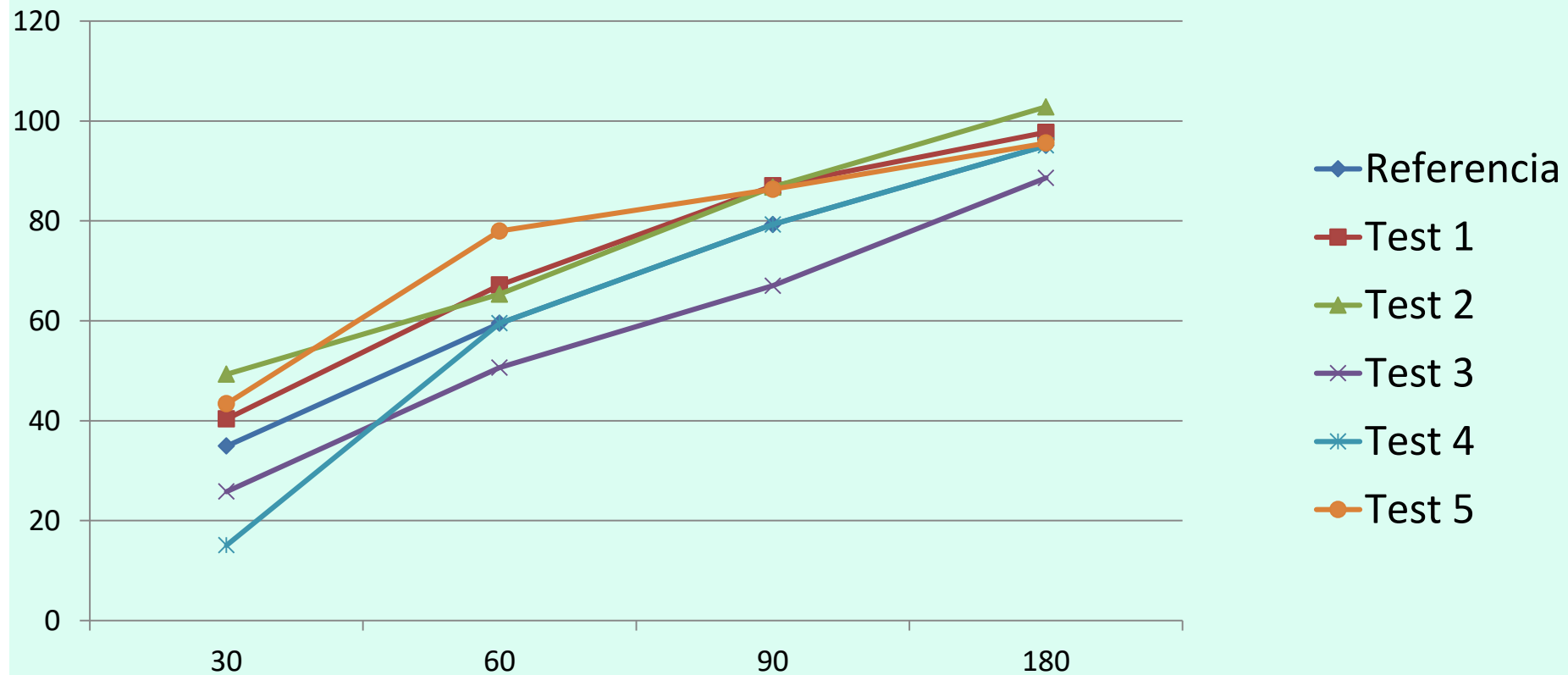

# Generic preparations

## In vitro similarity

If the similarity factor is  $f_2 > 50$ , then the dissolution profiles can be considered as similar.

Table 1. Dissolution data for calculating  $f_2$  values<sup>11</sup>

Reference			Test 1			Test 2		
Time	Mean	SD	Time	Mean	SD	Time	Mean	SD
30	34.92	2.26	30	40.34	4.1	30	49.33	2.32
60	59.5	3.85	60	67.15	6.34	60	65.33	5.02
90	79.27	5.12	90	87.01	4.76	90	86.75	3.52
180	95.08	6.14	180	97.73	1.48	180	102.83	1.72
			$f_2=60.04$			$f_2=51.08$		
Test 3			Test 4			Test 5		
Time	Mean	SD	Time	Mean	SD	Time	Mean	SD
30	25.8	2.36	30	15.08	5.78	30	43.39	1.29
60	50.64	4.64	60	59.5	3.07	60	77.95	1.43
90	67	6.14	90	79.27	4.32	90	86.33	2.8
180	88.6	8.12	180	95.08	2.68	180	95.58	1.99
$f_2=51.19$			$f_2=50.07$			$f_2=48.05$		

The unit of time is minute, Mean represents mean of 12 observations, SD is standard deviation.  
 $f_2$  was calculated using mean values, weight was equal to one.

# Generic preparations

## IVIVC

**Correlation between in vitro and in vivo** data (IVIVC) is often used in pharmaceutical development to reduce development time and optimize formulation.

IVIVC allows optimization of the drug formulation with as few human studies as possible, fixes dissolution criteria, acceptance criteria and can be used as a substitute bioequivalence assay.

# Generic preparations

## IVIVC

Relationship between BCS and expected IVIVC for sustained release formulations.

BCS Class	Solubility	Permeability	IVIVC
I/a	good	good	IVIVC Expected
I/b	good	Narrow absorption window	IVIVC Expected
II/a	poor	Good	IVIVC Várható
II/b	poor	Narrow absorption window	slight, or not expected IVIVC
III.	poor	good	IVIVC Not expected
IV.	Poor	poor	IVIVC Not expected
V/a (alkaline materials)	variable (upper part of the GI tract only)	Variable	IVIVC expected
V/b (acidic materials)	variable (lower part of the GI tract only)	variable	slight, or not expected IVIVC

# Generic preparations

## IVIVC

Relationship between BCS and the expected IVIVC  
**fast release formulations**

IVIVC **should not be used** in **immediate release oral systems**.

As a result of the immediate release, the rate of absorption is independent of dissolution, only dependent on the rate of gastric emptying and / or intestinal permeability.

# Generic preparations

## IVIVC

IVIVC is **generally used** when **drug release is the rate-limiting** step for in vivo absorption.

The use of IVIVC is restricted to certain active ingredients and can only be used for the same formulation. It should not be used between different dosage forms, especially in the case of different release products.

# Generic preparations

BCS	API parameters		Formulation options		Dissolution IVIVC
	solubility	permeability	peroral	parenteral	
1	High	High	+	+	IVIVC is only expected <b>if the dissolution rate is less</b> than the gastric emptying time
2	Low	High	Solubility increasing, Solution form, Solid dispersion, Particle size decreasing	-	IVIVC can only be expected <b>if the in vitro dissolution rate is similar to the in vivo</b> one
3	High	Low	Absorption promotion	+	Slow absorption is the determinant of speed, therefore, <b>IVIVC is limited</b>
4	Low	Low	Combining 2. and 3.	-	<b>IVIVC is limited or non-existent</b>

# Generic preparations

## IVIVC

The IVIVC can be used:

- prolonged-release preparations,
- changing the tablet excipient,
- when manufacturing technology changes



# Generic preparations

reference

generic

Identical  
raw materials  
production



Identical  
raw materials  
production

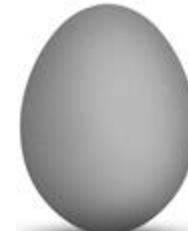
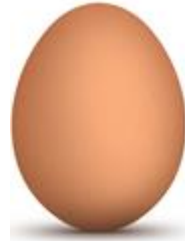

Differences:

color,  
psychic effect,  
trust

Confusing factors  
for the consumer

# Generic preparations

**reference**

**generic**

**Identical**  
formulations,  
active ingredient  
drug content  
GMP,  
dissolution,  
bioequivalence

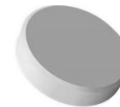
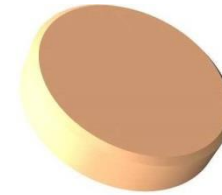

**Identical**  
formulations,  
active ingredient  
drug content  
GMP,  
dissolution,  
bioequivalence

**Differences:**

- appearance (color, shape, size),
- psychic effect (trust),
- excipient composition,
- wrapping,
- price

Confusing factors  
for the consumer

# Supergeneric preparations

A **supergeneric drug** is a generic formulation that contains the **same active ingredient** as the original (reference) formulation, but has **some other therapeutically beneficial properties**, e.g. patient management and therapeutic cooperation of the patient may be improved.

**If the manufacturer may be planning a different therapeutic application from the original, it should be aware that further clinical trials are needed.**

**If the indication of the developed product is different from the reference product, it must be supported by appropriate clinical trial or literature data.**

# Supergeneric preparations

During the long, mostly 20 years of the patent protection of the drug, the drug technology can significantly improve (new pharmaceutical forms, more advanced excipients, regulatory possibilities can be applied).

Options for change:

- in the recommendation,
- in the administration mode,
- in potency,
- in pharmaceutical form,
- in the formulation of excipients
- in packaging, and they are of some kind
- combination.

# Supergeneric preparations

The active substance can be added to the product range by referring to the previous registration (modifying it by the "abridged" simplified registration procedure prior to registration).

These drugs are called "supergeneric" or "generic plus" formulations.

# Generic preparations

## Substitutability

**Replacement of original agent is not recommended! (*incomplete list*)**

- Narcotics (eg anticonvulsants, eg phenytoin, carbamazepine and valproate, digoxin, warfarin)
- Antihypertensive agents (eg, hydralazine, combination of reserpine and hydrochlorothiazide, combination of reserpine and hydroflumethiazide)
- Inhalation aerosol formulations, especially anti-asthma agents (eg metaproterenol and terbutaline, some inhaled corticosteroids)
- Hormones (eg estrogenic esterified products)
- Other preparations (eg disulfiram, fluoxymesterone, mazindol, nicotine patches, phenytoin (fast acting), promethazine tablets and suppositories, rauwolfia serpentina and trichloromethiazide).

**Thank you for your attention!**

